



MVX
Soft Starter

AuCom

DANGER
HIGH



MVX

MVX

Smaller size: The overall form factor is 60% smaller than our previous product MVS. The MVX is among the smallest medium voltage soft starter in its class. Smaller size is a big advantage in lowering the costs in building and provides more flexibility where space is limited, for example marine applications.

INCREASED SAFETY

To ensure that your staff and plant are safe from arc faults, MVX is the only choice. MVX meets or exceeds all the relevant standards:

- IEC62271-200 for switchgear and apparatus, and internal arc fault resistance
- IEC62271-304 for switchgear and apparatus
- IEC60664-1 for electrical insulation

EASIER TO SERVICE

AuCom has eliminated complex disassembly to replace or service a part, AuCom MVX panels are designed with easy rack in-rack out operation, and components are easily accessible via hinged doors or removable panels while still keeping unauthorised people out.

MORE FLEXIBILITY

Don't feel constrained in the choice of apparatus in your switchgear, AuCom panels are compatible with all of the major apparatus suppliers.

THE BENEFIT OF EXPERIENCE

At every stage of the process your AuCom team will work hard to create the ideal AuCom solution to meet the needs of your application and budget.

Bus bars isolated in separate compartment



Viewing window to inspect fuses, earth switch etc without opening doors





SOFT STARTER PHASE CASSETTE FEATURES



RACK-IN/RACK-OUT

AuCom MVX soft starters are fully self-contained and easily serviced/replaced. AuCom can include a service trolley that enables one person to remove and replace the starter. Phase cassettes are installed via a rolling base which is easily integrated for OEM solutions.

STANDARD COMPATIBILITY

All panels are constructed around 150 mm pole centres for compatibility with standard apparatus options from major suppliers. Soft starters are also built to plug in/out easily.

SMALL FOOTPRINT

The compact size of the starter allows for a smaller overall panel dimension to save space in your switch room. Robust construction allows for reliable use in even the most demanding industrial locations.



KEYPAD

REAL LANGUAGE

The MVX features simple, plain language feedback on the soft starter's operation and events – no trip code look-ups. The MVX has language options for operation in English and Chinese.

EASY TO READ SCREEN

The MVX has a real-language display, offering extensive feedback and real-time status information in an easy-to-read format. Comprehensive metering information, details of starter status and last start performance allow easy monitoring of the starter's performance at all times. Multiple status screens let you display the data most relevant to your application, or you can configure your own program-mable screen to show the most relevant information for your application.

EVENT LOGS

A 99 position event log records all information on the starter's operating history, in separate event and trip logs to assist in troubleshooting. An eight position trip log records trip states and operating conditions at the time of trip.

- Phase currents and voltages
- Mains frequency
- Starter state
- Time and date



MULTILINGUAL CONTROLLER FOR OPERATION IN ENGLISH AND SIMPLIFIED CHINESE

CLEAR, EASY TO READ SCREEN

STATUS LEDS FOR IMMEDIATE FEEDBACK

START, STOP, RESET, LOCAL/ REMOTE PUSH BUTTONS

SHORTCUT BUTTONS FOR QUICK ACCESS TO COMMON TASKS

IP65 KEYPAD MOUNTED ON CABINET EXTERIOR

ALL CONTROLS CENTRALLY LOCATED ON A SINGLE PANEL

EMERGENCY STOP BUTTON



CENTRALISED CONTROL

All control of the soft starter is available from the single controller. The graphical display even allows real-time graphing of the starter operation. Isolated control is provided via fibre optic connections between the LV and MV sections.



SPECIFICATIONS

General

Current Range up to 800 A
 Motor connection In-line

Supply

Mains Voltage (L1, L2, L3) up to 13800 V
 Control Voltage 110~240 VAC
 Mains Frequency 45 Hz to 66 Hz

Inputs

Inputs Active 24 VDC, 8 mA approx.
 Start (C23, C24) 24 VDC, 8mA approx.
 Stop (C31, C32) 24 VDC, 8mA approx.
 Reset (C41, C42) 24 VDC, 8mA approx.
 Input A (C53, C54) 24 VDC, 8mA approx.
 Input B (C63, C64) 24 VDC, 8mA approx.
 Motor Thermistor (B4, B5)

Outputs

Relay outputs 10 A at 250 VAC/360 VA
 10 A at 30 VAC resistive
 Main Contactor (Terminals 13, 14) Normally Open
 Bypass Contactor (Terminals 23, 24) Normally Open
 Run Output/ PFC (Terminals 33, 34) Normally Open
 Output Relay A (Terminals 43, 44) Normally Open
 Output Relay B (Terminals 51, 52, 54) Changeover
 Output Relay C (Terminals 61, 62, 64) Changeover
 Analog Output (Terminals B10, B11) 0-20 mA or 4-20 mA

Environmental

Protection
 Power Assembly IP00
 Controller IP54/ NEMA 12
 Operating Environment (IEC60721-3-3) -5 °C to 55 °C
 (air conditioning may extend this range)
 Storage Temperature -25 °C to 55 °C
 Relative Humidity 95% non-condensing
 Conformal coating of PCBs Standard

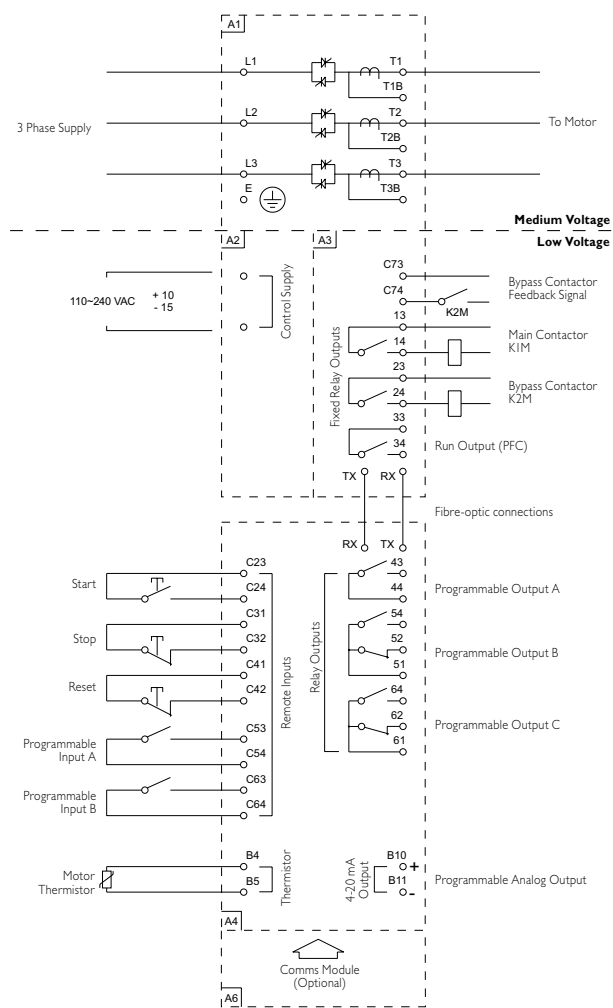

Item	Description
A1	Power Assembly
A2	Control Voltage Terminal Block
A3	Power Interface PCB
A4	Controller
A6	Comms Module (Optional)
K1M	Main Contactor
K2M	Bypass Contactor





DIMENSIONS

PHASE CASSETTES

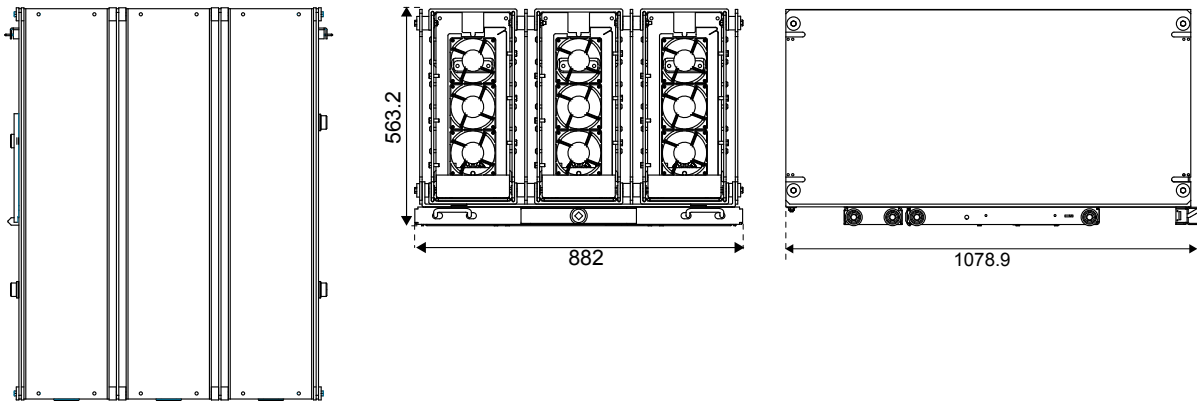

PANELS

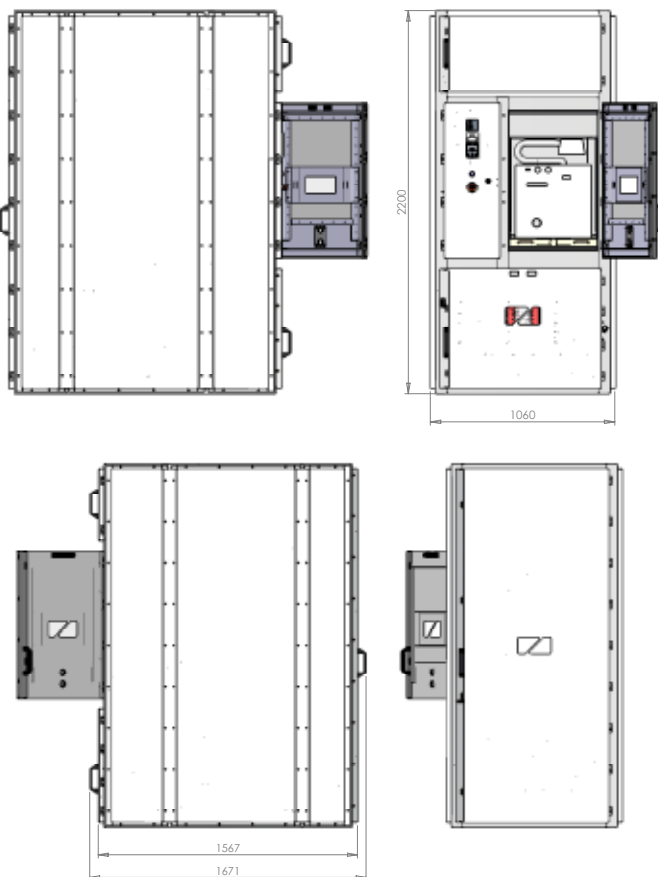



PANEL COMPARTMENTS

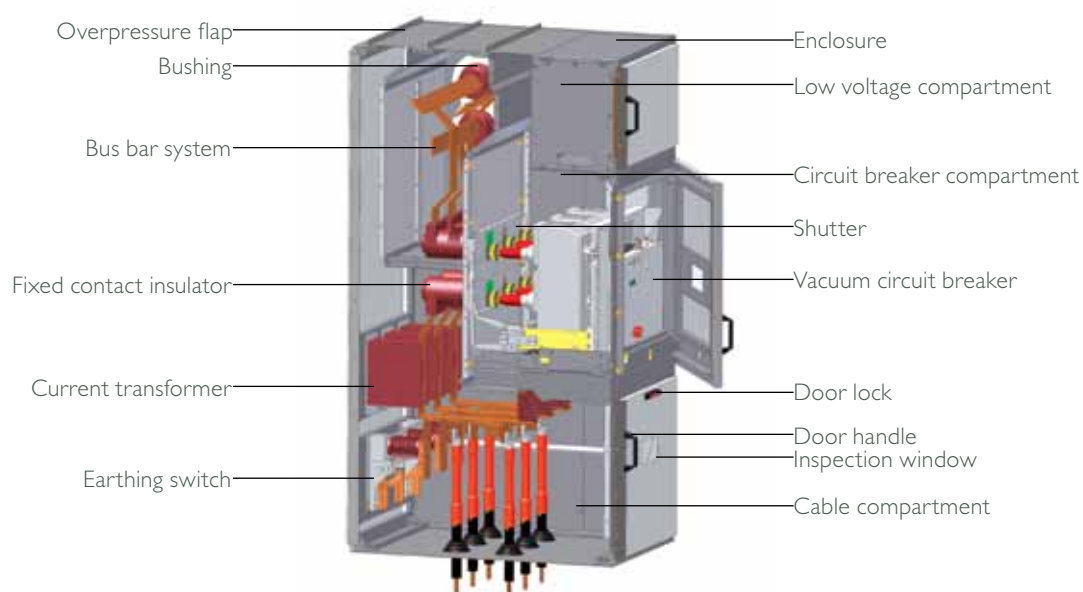

PANEL COMPARTMENTS

Each panel consists of four compartments: Bus bar compartment, cable compartment, circuit breaker compartment and the instrument compartment

The bus bar compartment houses the main bus bar system connected to the fixed upper isolating contacts of the circuit breaker by means of branch connections.

The cable compartment houses the connection of the power cables to the bus bar. The earthing switch, surge arresters, voltage and current transformers can be installed here.

The circuit breaker compartment houses the bushing insulators containing fixed contacts for the connection of the circuit breaker with the bus bar and the cable compartment.

COMPARTMENT SEGREGATION

Metallic shutters and partitions segregate the compartments from each other. When a compartment is opened all other panels in the installation and all cable termination compartments (including that in the panel concerned) remain in operation.

Metallic shutters automatically protect high voltage components when the circuit breaker is withdrawn.

All switching operations can be performed with the doors closed and the position of the circuit breaker can be seen from the front of the panel through a pressure-resistant inspection window.

AVAILABILITY AND PARTITION

L-Series panels are designed in compliance with availability classes LSC2B and partition class PM according to IEC 62271-200.

The switchgear compartments do not need any tools for opening. Interlocks allow access only when the corresponding high voltage parts are dead and earthed.



SAFETY

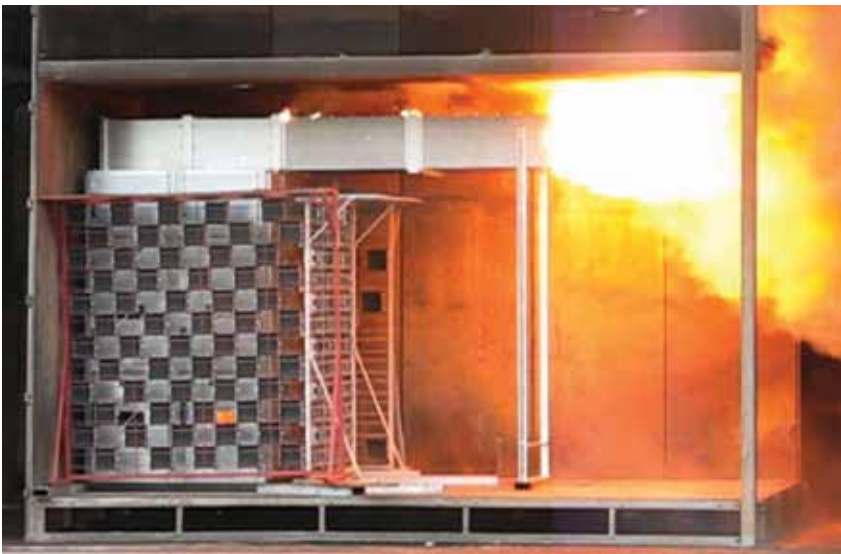

Internal arc fault test, 31.5kA/1s

ARC FAULT

An arc fault is a high power discharge of electricity between two or more conductors. The event can reach temperatures of 10,000° C, hot enough to liquefy ceramics, plastics and metal.

The arc fault causes a sudden increase in pressure, followed by an expansion, emission phase and finally a thermal phase. This can blast the debris and combustible gas outward with extreme force.

The internal pressure against the weakest points of the enclosure (e.g. windows, hinges and joints) can destroy an electrical enclosure and may cause serious or fatal injury to nearby personnel.

Arc faults can occur for a number of reasons, usually overvoltage, faulty insulation, mechanical failure or failure of a fuse.

ARC FAULT PROTECTION

If an arc event occurs within an AuCom L-Series panel, the arc fault is contained by solid locking doors and heavy double layer compartment panels.

During the emission phase the pressure is safely released using discharge flaps on the top of the panel (or optional ducts). These direct the explosion upwards or vent it safely outside.

Arc fault events normally occur in less than a second, so not even the fastest person is able to react to protect themselves. However pressure discharge flaps will react in milliseconds to allow the heated gases to vent.

Responsible specifiers should ensure that they require all switchgear to meet IEC 62271-200. L-Series panels are suited for Internal Arc Classification (IAC) AFLR to a maximum of 31.5 kA for 1 second.



Type test reports

TESTS

AuCom L-Series panels have passed arc fault tests for the entire range of panel enclosures. (Type test certificates are available on request). The panels will even pass arc fault tests with low voltage compartment doors open.

All L-Series panels are fully type tested according to IEC 62271-200:

- Short time and peak withstand current
- Temperature rise and main circuit impedance
- Dielectric test on main and auxiliary circuits
- Making and breaking capacity of the circuit breaker within the panel
- Earthing switch making capacity
- Mechanical operations
- Internal arc fault (IAC classified: AFLR, 31.5A/1s)



TESTING AND SIMULATION

LOW VOLTAGE TESTING

The MVX can be connected to a low voltage motor (≤ 500 VAC) for testing. This allows the user to thoroughly test the soft starter and its associated power and control circuits. The low voltage test mode provides a means of testing the soft starter's configuration without requiring a full medium voltage test facility.

SOFTWARE SIMULATIONS

The simulations function allow the MVX to be tested without a motor connected, to confirm that the soft starter's control circuits are operating correctly. There are three simulation modes available:

- Run simulation: simulates a motor starting, running and stopping to confirm correct configuration of main and bypass contactors, fibre-optic controls, programmable relays and motor control signals.
- Protection simulation: simulates activation of each protection mechanism to confirm that the soft starter is responding correctly in each situation.
- Signalling simulation: simulates output signalling to confirm configuration.

RATINGS

AuCom selects each MVX to suit your needs. Choose a starter to suit your site conditions such as altitude, ambient temperature, load, and starts per hour.

AuCom MVX ratings are detailed using the AC53b utilisation code. An example is shown below.

165 A:AC-53b 5-30 : 1770

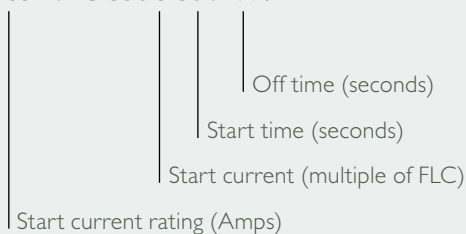

STARTER CURRENT RATING

The full load current rating of the soft starter given the parameters detailed in the remaining sections of the utilisation code.

START CURRENT

The maximum available start current as a multiple of FLC.

START TIME

The maximum time required to start the motor at the rated start current.

OFF TIME

The minimum allowable time between the end of one start and the beginning of the next start.



PROTECTION

PROTECTION

A wide range of protection features ensure your equipment can operate safely in the most demanding environments. Each protection can be individually adjusted to the required sensitivity, or can be disabled if required to ensure vital equipment continues to operate even in the most challenging situations.

TRIPS

Trips and warnings are written to an eight-place trip log, together with information on motor and system status at the time, speeding up analysis of problems.

DESIGN

- Depending on the design all compartments are accessible from the front. Alternatively the cable compartment is accessible from the rear.
- Cable connection points are all at comfortable height.
- Cable and circuit breaker compartments include pressure resistant inspection windows as standard.
- Fully flexible cabling and bus bar entry option
- Created for simple, straightforward manufacturing: No welding, balancing, grinding or cleansing procedures are required.
- Segregated bus bars from panel to panel.
- Optional arc venting shields or gas exhaust duct available.

THERMAL CAPACITY

The thermal model will only permit a start which is predicted to succeed. This protects the motor against overloads which shorten the motor life.

ADVANCED THERMAL MODELLING

Intelligent thermal modelling allows the soft starter to dynamically calculate motor temperature to predict whether the motor can successfully complete a start. The MVX uses information from previous and upcoming starts to calculate the motor temperature to predict the motor's available thermal capacity.

PASSWORD PROTECTION

A multi-level password system provides security for parameter adjustments while still allowing users full access to the many metering functions.

FIBRE OPTICS

Electrical isolation of low and high voltage circuits is assured by a two line fibre-optic interface between the power assembly and the control module. This fibre-optic link simplifies installation of chassis mount MVX units into custom switchboards.

PROTECTION CODES

ANSI Code	Description	MVX Protection (built-in)
48	Maximum start time	Excess start time
66	Too many starts	Restart delay and dynamic thermal model
37	Undercurrent	Undercurrent
51L	Load Increase (alarm)	High current frequency output
51R	Overcurrent - jam	Excess start time, electronic shearpin
50	Overcurrent - short	Shorted SCR, electronic shearpin
49/51	Thermal overload	Thermal overload - dynamic model
46	Current imbalance	Current imbalance
	Positive/negative phase sequence	Phase sequence
27	Undervoltage	Undervoltage
59	Overvoltage	Overvoltage
47	Phase loss	Phase loss
47	Phase sequence	Phase sequence
50G	Ground fault	Ground fault
85	Communications failure	Communications failure
85	Internal failure	Internal failure
94/95	Ext. fault I/code - 1	Auxiliary trip A
	Ext. fault I/code - 2	Auxiliary trip B
23	Motor overtemperature	Thermistor protection*
49	Stator winding overtemperature	Thermistor protection*
32	Under power	Power Loss

* RTD Relay is an optional extra.



SAFETY FEATURES



Interlock for circuit breaker compartment door



Rounded edges guarantee safe handling



Swinghandle locks on the doors provide additional safety

ISOLATION

MVX panels use a combination of air and GP03 insulation and features to ensure personnel safety when working in the MV environment. Unlike messy oil or water insulation, GP03 is able to provide a smaller overall dimension without the hassle or reliability issues.

Fibre-optic insulation between the low voltage controller and the high voltage power assembly provides complete electrical isolation.

ENCLOSURE

The enclosure is made of corrosion resistant hot dip galvanized steel sheets. Its design allows fast assembly with bolts only. No welding, balancing, grinding or cleansing is necessary, and no jigs are required for assembly.

Each panel is equipped with sidewalls. The special design provides an 8 mm air gap between two neighbouring panels. In the unlikely event of an internal arc, this design assures that the damage is limited to the panel where the fault occurred.

DOORS & LOCKS

The coated doors are made from galvanized sheet steel. Robust hinges and handles provide for convenient and safe closing. The closing mechanisms are available for left or right hand operation.

Every compartment door has built-in locking as standard. Tags may also be applied to indicate sections with work in progress.



STARTING AND STOPPING OPTIONS

CONSTANT CURRENT

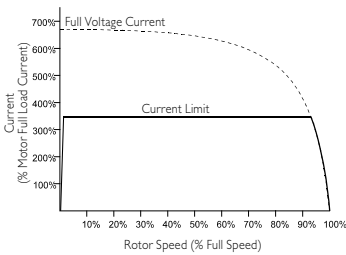

Suitable for most applications. Current is raised to specified level and held for duration of start.

CURRENT RAMP

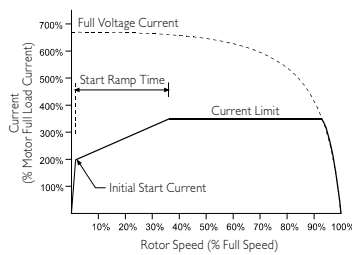

Better for generator sets or if conditions may vary between starts.

KICKSTART

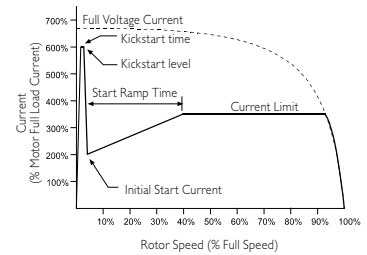

Provides a short boot of torque at the beginning of the start.

COAST TO STOP

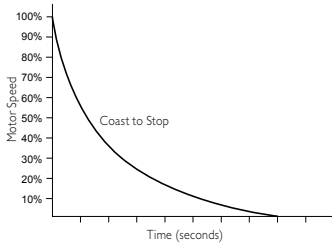

Removes voltage from motor and allows inertial slowing.

TIMED VOLTAGE RAMP

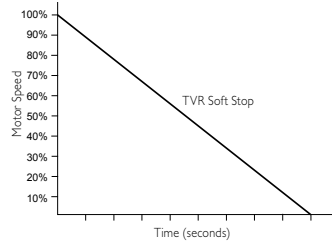

Gradually reduces voltage to extend deceleration time.

PUMP CONTROL STOP

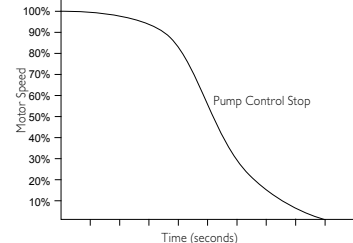

Provides gradual deceleration to reduce fluid hammer.



EQUIPMENT OPTIONS



Make-proof earthing switch

EARTHING SWITCH

Each feeder compartment can be equipped with an earthing switch for cable earthing.

When installed in measurement, bus-tie or bus riser panels it can also be used to earth the bus bar system.

The earthing switch has short circuit making capacity. The position of the earthing switch can be seen by means of mechanical position indication and in addition through an inspection window.

SWITCHING AND PROTECTION

- Earth Switch
- Vacuum Circuit Breakers
- Fuse contactor
- MOVs

Apparatus is easily installed by one person using the AuCom Service trolley. Equipment is rolled onto the service trolley and rolls into the panel via small track connectors.



Modbus, Profibus, DeviceNet and USB interface modules

COMMUNICATIONS

The MVX integrates into your existing monitoring and control network, using easy-to-install plug-in communication interfaces. The MVS supports Profibus, DeviceNet and Modbus RTU protocols. These modules are an optional extra.

POWER FACTOR CORRECTION OPTIONS

- Capacitors
- Inductors
- Fuses
- Contactors

AUXILIARY MODULES

- Measurement and protection current transformers
- Power meters
- Protection relays
- RTDs
- Inductive voltage transformers
- Panel heat pump
- Surge protection
- Protection relays



Surge Arresters

SURGE ARRESTERS

In the cable compartment space is provided for three fix mounted surge arresters to protect the equipment from switching overvoltages.



EQUIPMENT OPTIONS



Indoor support type current transformer and voltage transformer



Low duty circuit breaker



High duty circuit breaker

INSTRUMENT TRANSFORMERS

The panel is designed to be equipped with current transformers for measurement and protective purposes, toroidal current transformers and voltage transformers according to the dimensions of DIN 42600. For other transformers the panel can be adapted on request.



Connected power cable to the feeder busbar

POWER CABLES

Up to a maximum of 6 cables per phase can be used depending on the unit dimensions and the cable cross-section. Access to the cables is provided either from the front or from the rear. The cables enter the panel from the bottom. Optional top entry design is available.

VACUUM CIRCUIT BREAKER

MVX switchgear solutions are equipped as standard with an advanced vacuum circuit breaker which uses three single-coil magnetic actuators, one per pole. All switching elements are assembled along a single axis. All mechanical movements are therefore direct and linear. The three actuators are mounted in a steel frame and are mechanically linked by a synchronizing shaft.

This circuit breaker completely avoids failure of critical components such as

- mechanical latching
- gears, chains, bearings and levers
- tripping and closing coils
- motors to charge springs

The result is up to 150,000 C-O cycles at rated current or up to 100 operations at full short circuit breaking current without the need to replace or adjust any parts.

The vacuum circuit breaker is maintenance free over the total life expectancy of at least 25 years.

Customer-specified circuit breakers can be integrated on request.

OTHER AUCom PRODUCTS

AuCom offers a complete range of soft starters, with a solution for your soft starting requirement. Whether you need a simple product for starting only, or a comprehensive solution for your motor control and protection needs, you can trust AuCom to offer a product to match.

	Soft Start	Motor Protection	Advanced Interface	Internal Bypass	Power Range	Voltage Range
CSX	•			•	≤ 200 A	≤ 575 VAC
CSXi	•	•		•	≤ 200 A	≤ 575 VAC
IMS2	•	•	•		≤ 2361 A	≤ 690 VAC
EMX3	•	•	•	•	≤ 2400 A	≤ 690 VAC
MVS	•	•	•	•	≤ 600 A *	≤ 13.8 kV
MXV	•	•	•	•	≤ 800 A *	≤ 15 kV

* Higher ratings available on request.

CSX SOFT START CONTROLLER



An advanced soft start controller designed for use in motor control centres. Easily incorporated into any control circuit and suitable for use with any type of motor protection device.

CSXi COMPACT SOFT STARTER



A compact soft starter providing constant current soft start control and essential motor protection. A complete motor control solution in a single compact design.

EMX3 ADVANCED SOFT STARTER



A complete motor management system providing constant current, and current ramp as well as the new XLR-8, Adaptive Acceleration Control, available only from AuCom.

MVS MEDIUM VOLTAGE SOFT STARTER



An advanced motor management system for medium voltage motors. MVS soft starters provide a full range of soft start control, motor/load protection and other features.

For more information on AuCom products, contact your local distributor:

AuCom

AuCom Electronics Ltd.

123 Wrights Road
PO Box 80208
Christchurch 8440
New Zealand

T +64 3 338 8280

F +64 3 338 8104

E salesupport@aucom.com

W www.aucom.com

© 2011 AuCom Electronics. As AuCom is continuously improving its products it reserves the right to modify or change the specification of its products at any time without notice. The text, diagrams, images and any other literary or artistic works appearing in this brochure are protected by copyright. Users may copy some of the material for their personal reference but may not copy or use material for any other purpose without the prior consent of AuCom Electronics Ltd. AuCom endeavours to ensure that the information contained in this brochure including images is correct but does not accept any liability for error, omission or differences with the finished product.

710-11442-008